

LEDJ

TPix Strip & Controller MKII User Manual



Order code:

TPix Strip 40 MKII - LEDJ485

TPix Strip 80 MKII - LEDJ486

TPix Strip 40 Controller MKII - LEDJ487

TPix Strip 80 Controller MKII - LEDJ488

WARNING

FOR YOUR OWN SAFETY, PLEASE READ THIS USER MANUAL CAREFULLY BEFORE YOUR INITIAL START-UP!

- Before your initial start-up, please make sure that there is no damage caused during transportation.
- Should there be any damage, consult your dealer and do not use the equipment.
- To maintain the equipment in good working condition and to ensure safe operation, it is necessary for the user to follow the safety instructions and warning notes written in this manual.
- Please note that damages caused by user modifications to this equipment are not subject to warranty.



IMPORTANT:

The manufacturer will not accept liability for any resulting damages caused by the non-observance of this manual or any unauthorised modification to the equipment.

- Never let the power cable come into contact with other cables. Handle the power cable and all mains voltage connections with particular caution!
- Never remove warning or informative labels from the unit.
- Do not open the equipment and do not modify the unit.
- Do not connect this equipment to a dimmer pack.
- Do not switch the equipment on and off in short intervals, as this will reduce the system's life.
- Only use the equipment indoors.
- Do not expose to flammable sources, liquids or gases.
- Always disconnect the power from the mains when equipment is not in use or before cleaning! Only handle the power-cable by the plug. Never pull out the plug by pulling the power-cable.
- Make sure that the available mains supply voltage is between 100~240V AC, 50/60Hz.
- Make sure that the power cable is never crimped or damaged. Check the equipment and the power cable periodically.
- If the equipment is dropped or damaged, disconnect the mains power supply immediately and have a qualified engineer inspect the equipment before operating again.
- If the equipment has been exposed to drastic temperature fluctuation (e.g. after transportation), do not connect power or switch it on immediately. The arising condensation might damage the equipment. Leave the equipment switched off until it has reached room temperature.
- If your product fails to function correctly, stop use immediately. Pack the unit securely (preferably in the original packing material), and return it to your Pro Light dealer for service.
- Only use fuses of same type and rating.
- Repairs, servicing and power connection must only be carried out by a qualified technician. THIS UNIT CONTAINS NO USER SERVICEABLE PARTS.
- This lighting fixture is for professional use only - it is not designed for or suitable for household use. The product must be installed by a qualified technician in accordance with local territory regulations. The safety of the installation is the responsibility of the installer. The fixture presents risks of severe injury or death due to fire hazards, electric shock and falls.
- Warning! Risk Group 2 LED product according to EN 62471. Do not view the light output with optical instruments or any device that may concentrate the beam.
- WARRANTY: One year from date of purchase.

OPERATING DETERMINATIONS

If this equipment is operated in any other way, than those described in this manual, the product may suffer damage and the warranty becomes void. Incorrect operation may lead to danger e.g: short-circuit, burns and electric shocks etc.

Do not endanger your own safety and the safety of others!

Incorrect installation or use can cause serious damage to people and/or property.

PLEASE NOTE: THE MKII VERSIONS ARE NOT COMPATIBLE WITH THE MKI VERSIONS (LEDJ471/475).

TPix Strip & Controller MKII

The TPix strips are pixel mappable strips controllable by DMX, Art-Net or Kling-Net. They feature a wide 120° viewing angle and feature a milky, frost effect front screen. Black and clear front screens are included to further expand the versatility of these fixtures. The system is configured by using one controller for up to 16 strips arranged in four groups of four. The strips are easy to link with CAT5/CAT6 cable.

TPix Strip 40 MKII

- 40 tri-colour SMD 5050 LEDs (RGB)
- Illuminance: 1174 Nits - clear front screen
- Illuminance: 828 Nits - frosted front screen
- Illuminance: 728 Nits - black front screen
- Pixels: 40
- Pixel pitch: 25mm



Specifications	TPix Strip
Power consumption	16W (40) 32W (80)
Dimensions	37 x 1000 x 95mm
Weight	2kg
Order code	LEDJ485 (40) LEDJ486 (80)

TPix Strip 80 MKII

- 80 tri-colour SMD 5050 LEDs (RGB)
- Illuminance: 2348 Nits - clear front screen
- Illuminance: 1656 Nits - frosted front screen
- Illuminance: 1455 Nits - black front screen
- Pixels: 40
- Pixel pitch: 12.5mm

- Viewing angle: 120°
- 3.8kHz refresh rate
- TPix Strip requires the TPix Strip Controller MKII for operation (Order code: LEDJ487)
- Bracket allows for multiple rigging or floor standing applications
- RJ45 input/output (power/data)
- Convection cooled

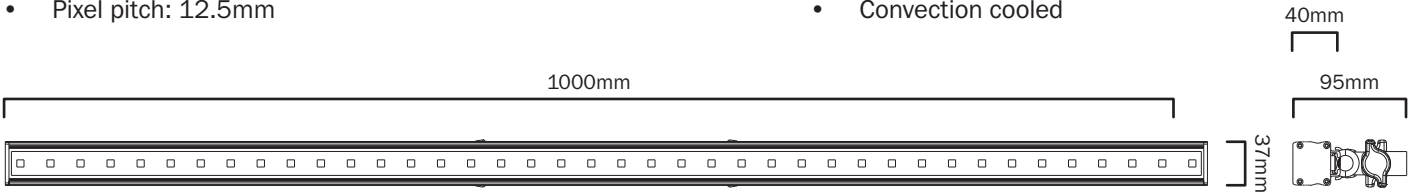

TPix Strip Controller

- DMX channels: 10/55 or 480 selectable
- Art-Net channels: 1920 (based on 16 strips of 120 channels each)
- 4 push button menu with LCD display
- 5-Pin XLR input/output
- 3-Pin XLR input/output
- Ethercon input/output (Art-Net/Kling-Net)
- Four RJ45 sockets for outputs to TPix Strip
- Refresh rate: 3.8kHz

Specifications	TPix Strip Controller MKII
Power consumption	500W
Power supply	100~240V, 50/60Hz
Fuse	F5A 250V
Dimensions	88 x 483 x 290mm
Weight	3.9kg
Order code	LEDJ487 (40) LEDJ488 (80)

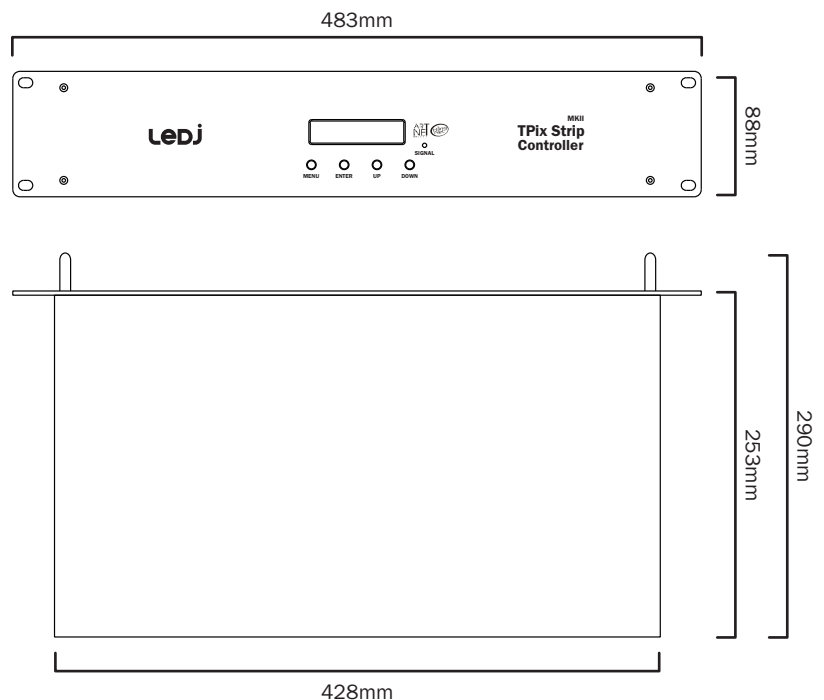

TPix Strip

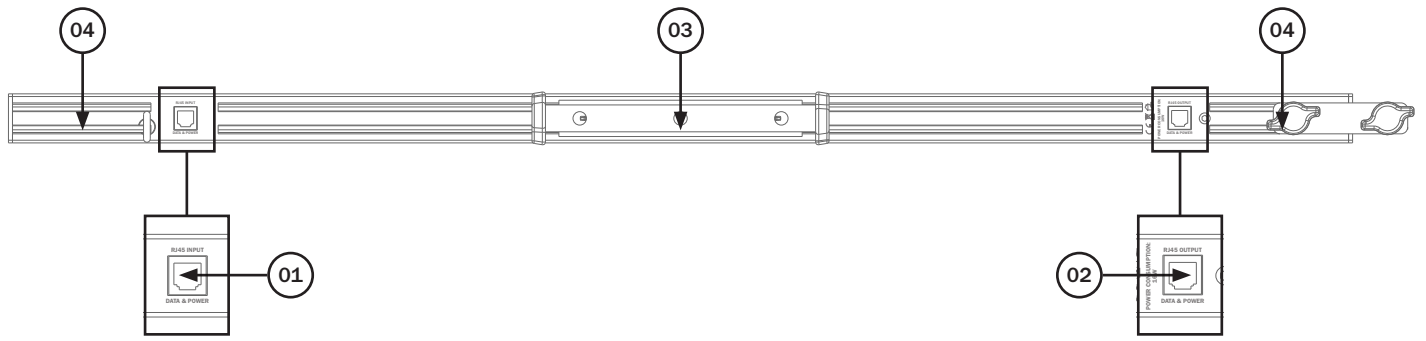

- 01 - RJ45 Data/Power input
- 02 - RJ45 Data/Power output

- 03 - Hanging bracket
- 04 - Panel to panel alignment brackets

In the box: **1 x fixture,**
1 x clear front screen,
1 x frosted front screen,
1 x black front screen,
1 x RJ45 signal cable
& 1 x user manual

TPix Strip Controller

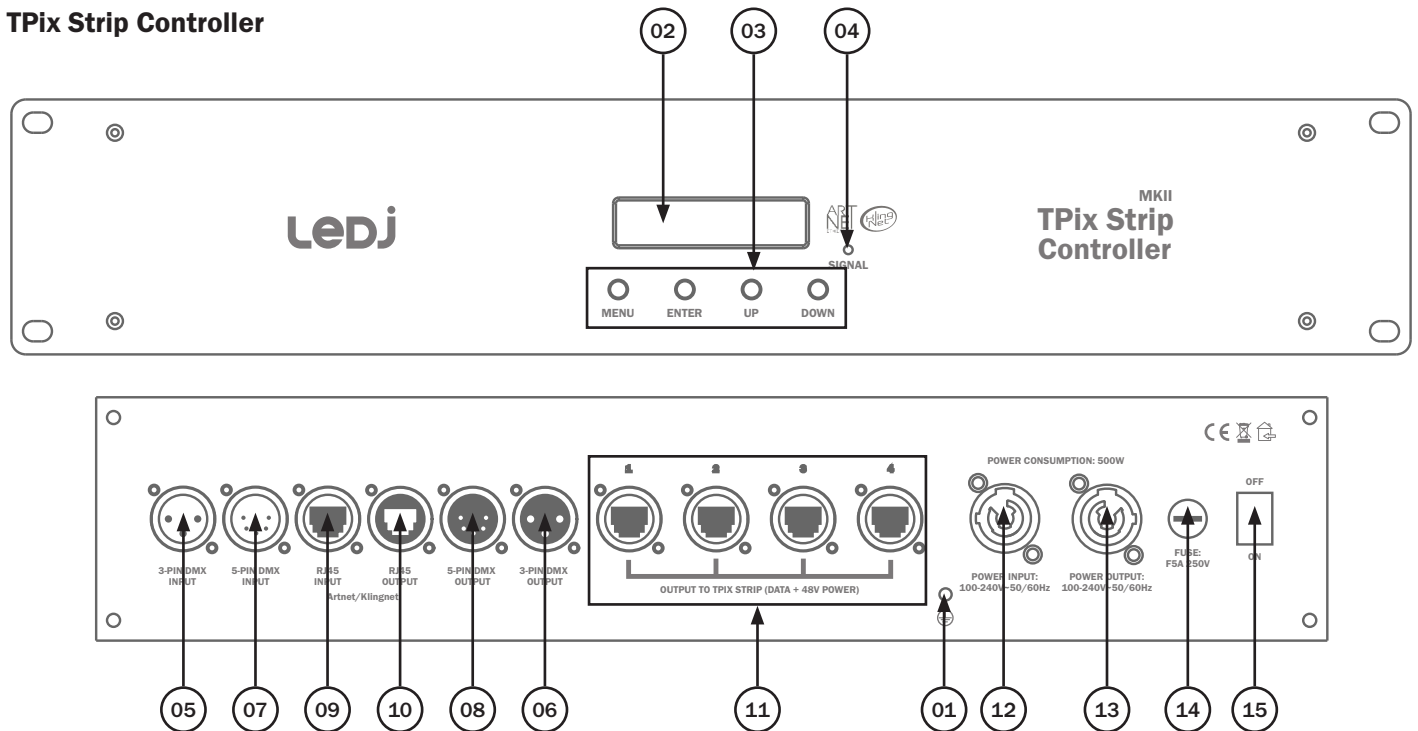

- 01 - Earth point
- 02 - LCD display
- 03 - Function buttons
- 04 - Signal LED
- 05 - 3-Pin DMX input
- 06 - 3-Pin DMX output

- 07 - 5-Pin DMX input
- 08 - 5-Pin DMX output
- 09 - RJ45 ArtNet/
KlingNet input
- 10 - RJ45 ArtNet/
KlingNet output

- 11 - Outputs to TPix Strip
- 12 - PowerCON input
- 13 - PowerCON output
- 14 - Fuse F5A 250V
- 15 - On/off switch

In the box: **1 x fixture,**
1 x PowerCON cable
& 1 x user manual

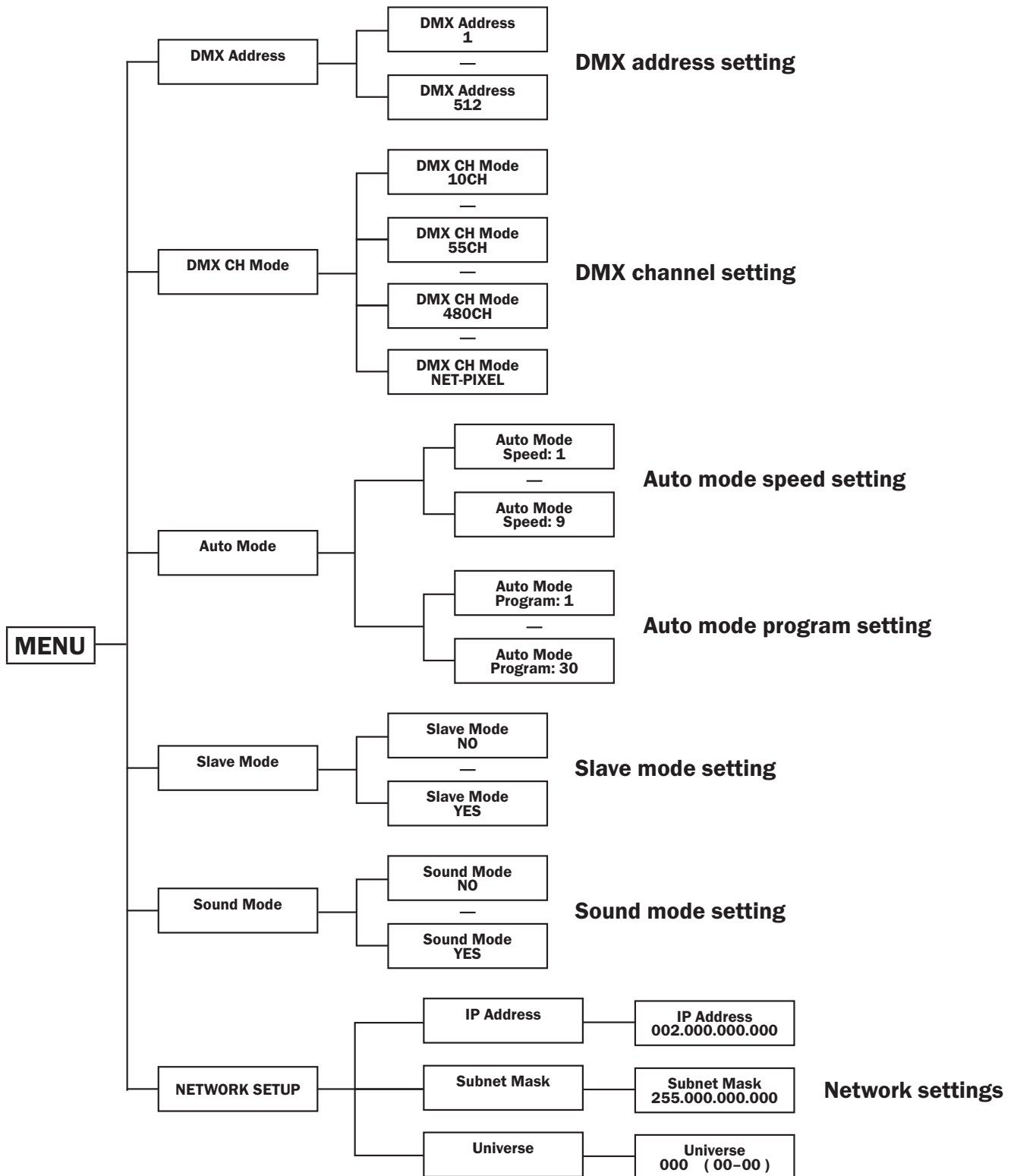

Press the “MENU” button followed by the “DOWN” buttons to show the software version.



IMPORTANT! PLEASE NOTE: The LCD display for this fixture has a timer that turns the display back-light off after 25 seconds of inactivity. To illuminate the display again press one of the 4 buttons.

DMX mode:

Operating in a DMX control mode environment gives the user the greatest flexibility when it comes to customising or creating a show. In this mode you will be able to control each individual trait of the fixture and each fixture independently.

To access the DMX address mode, press the **"MENU"** button and use the **"UP"** and **"DOWN"** buttons to show **"DMX Address"** on the LCD display. Now press the **"ENTER"** button and use the **"UP"** and **"DOWN"** buttons to set the required DMX address. Press the **"ENTER"** button to confirm the setting. To exit out of any of the above options, press the **"MENU"** button.

To access the DMX Channel mode, press the **"MENU"** button and use the **"UP"** and **"DOWN"** buttons to show **"DMX CH Mode"** on the LCD display. Now press the **"ENTER"** button and use the **"UP"** and **"DOWN"** buttons to set the required DMX channel mode (10/55/480). Press the **"ENTER"** button to confirm the setting. To exit out of any of the above options, press the **"MENU"** button.

10 channel mode:

Channel	Value	Function
1CH	000-255	Master dimmer (0-100%)
2CH	000-255	Strobe (slow-fast)
3CH	000-255	Red dimmer (0-100%)
4CH	000-255	Green dimmer (0-100%)
5CH	000-255	Blue dimmer (0-100%)
6CH (For macro colour use 9CH)	000-001	Blackout
	002-017	Macro 1
	018-034	Macro 2
	035-051	Macro 3
	052-068	Macro 4
	069-085	Macro 5
	086-102	Macro 6
	103-119	Macro 7
	120-136	Macro 8
	137-153	Macro 9
	154-170	Macro 10
	171-187	Macro 11
	188-204	Macro 12
	205-221	Macro 13
222-238	Macro 14	
239-255	Macro all	
7CH	000-001	Blackout
	002-017	Macro 1

Channel	Value	Function
7CH (cont.)	018-034	Macro 2
	035-051	Macro 3
	052-068	Macro 4
	069-085	Macro 5
	086-102	Macro 6
	103-119	Macro 7
	120-136	Macro 8
	137-153	Macro 9
	154-170	Macro 10
	171-187	Macro 11
	188-204	Macro 12
	205-221	Macro 13
	222-238	Macro 14
	239-255	Macro all
8CH	000-255	Macro speed (slow-fast)
9CH (Colour of 7CH macro)	0-36	Red
	37-73	Green
	74-110	Blue
	111-147	Yellow
	148-184	Cyan
	185-221	Pastel Pink
	222-255	White
10CH	000-255	Sound mode (colour change)

55 channel mode:

Channel	Value	Function
1CH	000-255	Master dimmer (0-100%)
2CH	000-255	Strobe (slow-fast)
3CH (For macro colour use 6CH)	000-001	Blackout
	002-017	Macro 1
	018-034	Macro 2
	035-051	Macro 3
	052-068	Macro 4
	069-085	Macro 5
	086-102	Macro 6
	103-119	Macro 7
	120-136	Macro 8
	137-153	Macro 9
	154-170	Macro 10
	171-187	Macro 11
	188-204	Macro 12
	205-221	Macro 13
	222-238	Macro 14
239-255	Macro all	
4CH	000-001	Blackout
	002-017	Macro 1
	018-034	Macro 2
	035-051	Macro 3
	052-068	Macro 4
	069-085	Macro 5
	086-102	Macro 6
	103-119	Macro 7
	120-136	Macro 8
	137-153	Macro 9
	154-170	Macro 10
	171-187	Macro 11
	188-204	Macro 12
	205-221	Macro 13
	222-238	Macro 14
239-255	Macro all	
5CH	000-255	Macro speed (slow-fast)
6CH (Colour of 4CH macro)	0-36	Red
	37-73	Green
	74-110	Blue
	111-147	Yellow
	148-184	Cyan

Channel	Value	Function	
6CH cont.	185-221	Pink	
	222-255	White	
7CH	000-255	Sound mode (colour change)	
8CH	000-255	Red dimmer (0-100%)	Output 1 Fixture 1
9CH	000-255	Green dimmer (0-100%)	
10CH	000-255	Blue dimmer (0-100%)	
11CH	000-255	Red dimmer (0-100%)	Output 1 Fixture 2
12CH	000-255	Green dimmer (0-100%)	
13CH	000-255	Blue dimmer (0-100%)	
14CH	000-255	Red dimmer (0-100%)	Output 1 Fixture 3
15CH	000-255	Green dimmer (0-100%)	
16CH	000-255	Blue dimmer (0-100%)	
17CH	000-255	Red dimmer (0-100%)	Output 1 Fixture 4
18CH	000-255	Green dimmer (0-100%)	
19CH	000-255	Blue dimmer (0-100%)	
20CH	000-255	Red dimmer (0-100%)	Output 2 Fixture 1
21CH	000-255	Green dimmer (0-100%)	
22CH	000-255	Blue dimmer (0-100%)	
23CH	000-255	Red dimmer (0-100%)	Output 2 Fixture 2
24CH	000-255	Green dimmer (0-100%)	
25CH	000-255	Blue dimmer (0-100%)	
26CH	000-255	Red dimmer (0-100%)	Output 2 Fixture 3
27CH	000-255	Green dimmer (0-100%)	
28CH	000-255	Blue dimmer (0-100%)	
29CH	000-255	Red dimmer (0-100%)	Output 2 Fixture 4
30CH	000-255	Green dimmer (0-100%)	
31CH	000-255	Blue dimmer (0-100%)	
32CH	000-255	Red dimmer (0-100%)	Output 3 Fixture 1
33CH	000-255	Green dimmer (0-100%)	
34CH	000-255	Blue dimmer (0-100%)	
35CH	000-255	Red dimmer (0-100%)	Output 3 Fixture 2
36CH	000-255	Green dimmer (0-100%)	
37CH	000-255	Blue dimmer (0-100%)	
38CH	000-255	Red dimmer (0-100%)	Output 3 Fixture 3
39CH	000-255	Green dimmer (0-100%)	
40CH	000-255	Blue dimmer (0-100%)	
41CH	000-255	Red dimmer (0-100%)	Output 3 Fixture 4
42CH	000-255	Green dimmer (0-100%)	
43CH	000-255	Blue dimmer (0-100%)	

55 channel mode:

Channel	Value	Function	
44CH	000-255	Red dimmer (0-100%)	Output 4 Fixture 1
45CH	000-255	Green dimmer (0-100%)	
46CH	000-255	Blue dimmer (0-100%)	
47CH	000-255	Red dimmer (0-100%)	Output 4 Fixture 2
48CH	000-255	Green dimmer (0-100%)	
49CH	000-255	Blue dimmer (0-100%)	
50CH	000-255	Red dimmer (0-100%)	Output 4 Fixture 3
51CH	000-255	Green dimmer (0-100%)	
52CH	000-255	Blue dimmer (0-100%)	
53CH	000-255	Red dimmer (0-100%)	Output 4 Fixture 4
54CH	000-255	Green dimmer (0-100%)	
55CH	000-255	Blue dimmer (0-100%)	

480 channel mode:

Channel	Value	Function	
1CH	000-255	Red dimmer (0-100%) LEDs 1-4 (40), 1-8 (80)	Output 1 Fixture 1
2CH	000-255	Green dimmer (0-100%) LEDs 1-4 (40), 1-8 (80)	
3CH	000-255	Blue dimmer (0-100%) LEDs 1-4 (40), 1-8 (80)	
4CH	000-255	Red dimmer (0-100%) LEDs 5-8 (40), 9-16 (80)	
5CH	000-255	Green dimmer (0-100%) LEDs 5-8 (40), 9-16 (80)	
6CH	000-255	Blue dimmer (0-100%) LEDs 5-8 (40), 9-16 (80)	
7CH	000-255	Red dimmer (0-100%) LEDs 9-12 (40), 17-20 (80)	
8CH	000-255	Green dimmer (0-100%) LEDs 9-12 (40), 17-20 (80)	
9CH	000-255	Blue dimmer (0-100%) LEDs 9-12 (40), 17-20 (80)	
.....	
478CH	000-255	Red dimmer (0-100%) LEDs 37-40 (40), 77-80 (80)	Output 4 Fixture 4
479CH	000-255	Green dimmer (0-100%) LEDs 37-40 (40), 77-80 (80)	
480CH	000-255	Blue dimmer (0-100%) LEDs 37-40 (40), 77-80 (80)	

ArtNet/KlingNet mode:

Please note: For full pixel control, ArtNet/KlingNet must be used with the fixture in PIXEL-NET mode. This will allow full control of each pixel.

To access the ArtNet/KlingNet mode, press the “**MENU**” button and use the “**UP**” and “**DOWN**” buttons to show “**DMX CH Mode**” on the LCD display. Now press the “**ENTER**” button and use the “**UP**” and “**DOWN**” buttons to select “**PIXEL-NET**”. Press the “**ENTER**” button to confirm the setting.

To exit out of any of the above options, press the “**MENU**” button.

Auto mode:

To access the Auto mode, press the “**MENU**” button and use the “**UP**” and “**DOWN**” buttons to show “**Auto Mode**” on the LCD display. Now press the “**ENTER**” button and use the “**UP**” and “**DOWN**” buttons to select either “**Speed**” or “**Program**”.

When selecting “**Speed**” press the “**ENTER**” button and use the “**UP**” and “**DOWN**” buttons to select between “**Speed: 1**” ~ “**Speed: 9**”.

When selecting “**Program**” press the “**ENTER**” button and use the “**UP**” and “**DOWN**” buttons to select between “**Program: 1**” ~ “**Program: 30**”.

Press the “**ENTER**” button to confirm the setting.

To exit out of any of the above options, press the “**MENU**” button.

Master/slave mode:

To set the master unit, press the “**MENU**” button and use the “**UP**” and “**DOWN**” buttons to select one of the Auto Programs.

To set the other units in slave mode, press the “**MENU**” button and use the “**UP**” and “**DOWN**” buttons to show “**Slave Mode**” on the LCD display. Now press the “**ENTER**” button and use the “**UP**” and “**DOWN**” buttons to set slave mode on/off “**Slave Mode [YES]**” or “**Slave Mode [NO]**”.

Press the “**ENTER**” button to confirm the setting.

Sound mode:

To set sound mode, press the “**MENU**” button and use the “**UP**” and “**DOWN**” buttons to show “**Sound Mode**” on the LCD display. Now press the “**ENTER**” button and use the “**UP**” and “**DOWN**” buttons to set slave mode on/off “**Sound Mode [YES]**” or “**Sound Mode [NO]**”.

Press the “**ENTER**” button to confirm the setting.

IP Address setting:

To access the IP address setting, press the “**MENU**” button and use the “**UP**” and “**DOWN**” buttons to show “**NETWORK SETUP**” on the LCD display. Now press the “**ENTER**” button and use the “**UP**” and “**DOWN**” buttons to select “**IP Address**”. Press the “**ENTER**” button and use the “**UP**” and “**DOWN**” buttons to select the part of the IP address you would like to change indicated by three downward arrows. Press the “**ENTER**” button and use the “**UP**” and “**DOWN**” buttons to adjust the selected part of the IP address you have chosen. Press the “**ENTER**” button to confirm the setting.

To exit out of any of the above options, press the “**MENU**” button.

Subnet Mask setting :

To access the Subnet Mask setting, press the “**MENU**” button and use the “**UP**” and “**DOWN**” buttons to show “**NETWORK SETUP**” on the LCD display. Now press the “**ENTER**” button and use the “**UP**” and “**DOWN**” buttons to select “**Subnet Mask**”. Press the “**ENTER**” button and use the “**UP**” and “**DOWN**” buttons to select the part of the Subnet mask you would like to change indicated by three downward arrows. Press the “**ENTER**” button and use the “**UP**” and “**DOWN**” buttons to adjust the selected part of the Subnet mask you have chosen. Press the “**ENTER**” button to confirm the setting.

To exit out of any of the above options, press the “**MENU**” button.

Universe setting:

To access the Universe setting, press the “**MENU**” button and use the “**UP**” and “**DOWN**” buttons to show “**Network Settings**” on the LCD display. Now press the “**ENTER**” button and use the “**UP**” and “**DOWN**” buttons to select “**Net SubNet Universe**”. Press the “**ENTER**” button and use the “**UP**” and “**DOWN**” buttons to select the part of the Net SubNet Universe you would like to change indicated by three downward arrows. Press the “**ENTER**” button and use the “**UP**” and “**DOWN**” buttons to adjust the selected part of the Net SubNet Universe you have chosen.

Press the “**ENTER**” button to confirm the setting.

To exit out of any of the above options, press the “**MENU**” button.

Software version:

To access the fixtures software version, press the “**MENU**” button twice to show “**IP:X.X.X.XX**” and use the “**DOWN**” button to show “**Soft Version AML V1.0**” on the LCD display.

To exit out of any of the above options, press the “**MENU**” button.

KlingNet Settings:

- 01) Install a KlingNet based software on your PC (Windows or Mac).
- 02) Connect the TPix Strip to the TPix Strip Controller via the RJ45 outputs.
- 03) Connect the TPix Strip Controller to a power supply via the PowerCON input.
- 04) Make sure the PC has a fixed IP Address. No further network settings need to be adjusted.
- 05) Connect the TPix Strip Controller to your computer via a CAT-5/CAT-6 cable (see page 10). Once the fixtures have been connected they will be automatically recognised by the KlingNet based software.
- 06) Map the devices using the “drag and drop” method, placing the fixtures in the “on-screen” interface on the right position. This will take a few minutes and once done the system is fully set up.

Please note: When creating large setups, it is recommended to use a 16-bit, high speed ethernet switch to transmit the KlingNet data signal.

ArtNet Settings:

- 01) Install an ArtNet based software on your PC (Windows or Mac) or connect to an ArtNet enabled console. Please note: some consoles/software operate within dedicated IP ranges (i.e. Chamsys requires the 2.0.0.0 range). Please consult user documentation for the software/console for clarification.
- 02) Connect the TPix Strip to the TPix Strip Controller via the RJ45 outputs.
- 03) Connect the TPix Strip Controller to a power supply via the PowerCON input.
- 04) Connect the TPix Strip Controller to your software/controller via a CAT-5/CAT-6 cable (see page 10).
- 05) Set the IP address of the software/controller to 2.x.x.x or 10.x.x.x, depending on the ArtNet settings.
- 06) Set the Subnet mask to 255.0.0.0 on both the TPix Strip Controller and the software/controller. Make sure that all fixtures in the network have a unique IP address.

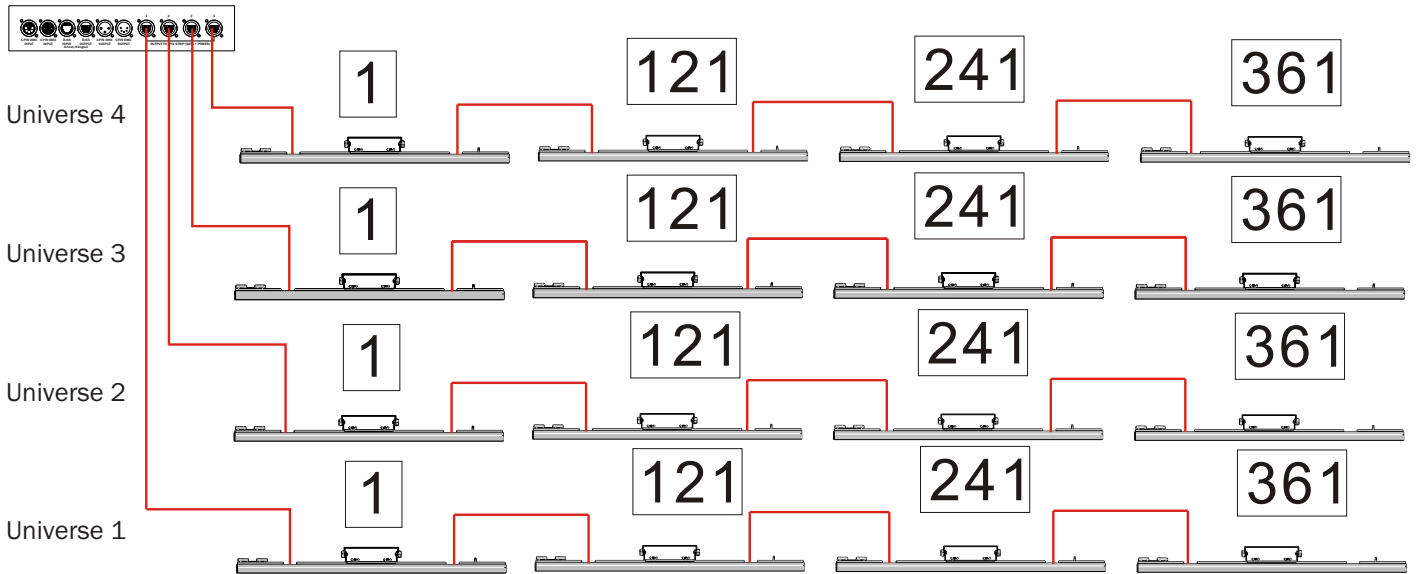

Please note: You must always go from the TPix Controller RJ45 output into a TPix Strip input and then from a TPix Strip RJ45 output to TPix Strip RJ45 input to link TPix Strips.

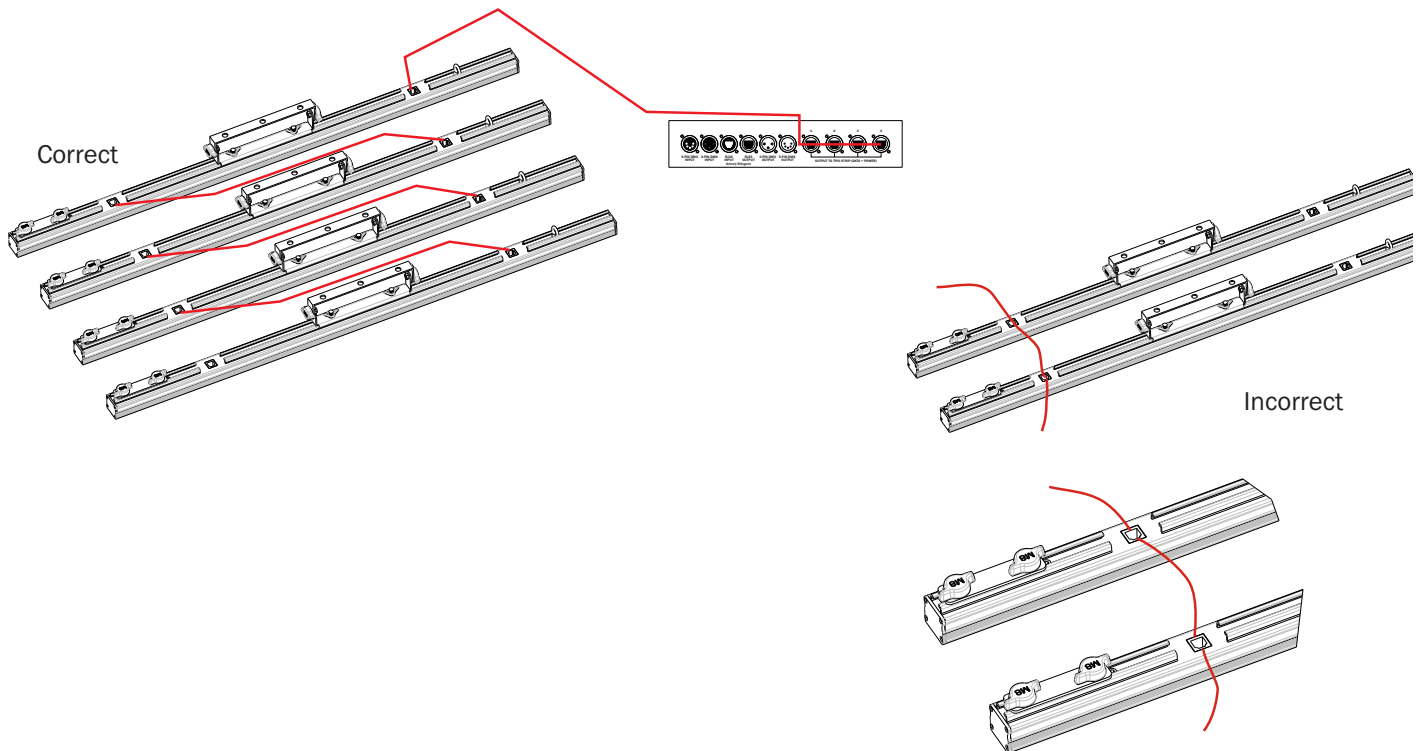

Making a data cable:

A standard ETHERNET cable can be used to replace the data cable required to transmit the data.





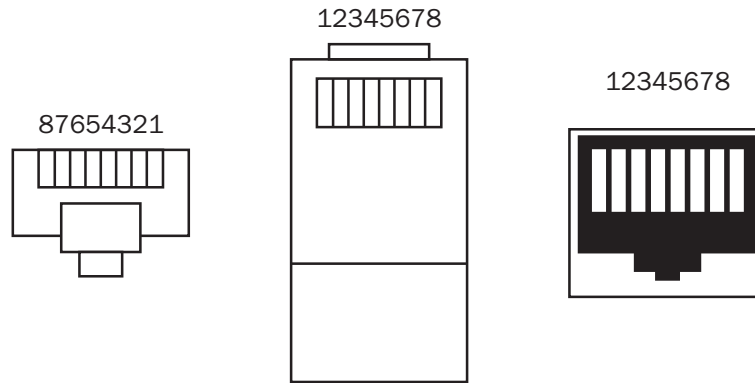





Please follow the instructions below in order to create extra cables:

Take a standard net cable (CAT-5/CAT-5E/CAT-6) and connect it to an RJ45 connector as shown below.



Colour Standard EIA/TIA T568A

Ethernet Patch Cable

		RJ45	Pin#		Pin#	RJ45	
TX +		Green/White Tracer	1	—	1	Green/White Tracer	 PR 3
TX -		Green	2	—	2	Green	 PR 3
RX +		Orange/White Tracer	3	—	3	Orange/White Tracer	 PR 2
		Blue	4	—	4	Blue	 PR 1
		Blue/White Tracer	5	—	5	Blue/White Tracer	 PR 1
RX -		Orange	6	—	6	Orange	 PR 2
		Brown/White Tracer	7	—	7	Brown/White Tracer	 PR 4
		Brown	8	—	8	Brown	 PR 4

Setting the DMX address:

The DMX mode enables the use of a universal DMX controller. Each fixture requires a “start address” from 1- 512. A fixture requiring one or more channels for control begins to read the data on the channel indicated by the start address. For example, a fixture that occupies or uses 7 channels of DMX and was addressed to start on DMX channel 100, would read data from channels: 100, 101, 102, 103, 104, 105 and 106. Choose a start address so that the channels used do not overlap. E.g. the next unit in the chain starts at 107.

DMX 512:

DMX (Digital Multiplex) is a universal protocol used as a form of communication between intelligent fixtures and controllers. A DMX controller sends DMX data instructions from the controller to the fixture. DMX data is sent as serial data that travels from fixture to fixture via the DATA “IN” and DATA “OUT” XLR terminals located on all DMX fixtures (most controllers only have a data “out” terminal).

DMX linking:

DMX is a language allowing all makes and models of different manufactures to be linked together and operate from a single controller, as long as all fixtures and the controller are DMX compliant. To ensure proper DMX data transmission, when using several DMX fixtures try to use the shortest cable path possible. The order in which fixtures are connected in a DMX line does not influence the DMX addressing. For example; a fixture assigned to a DMX address of 1 may be placed anywhere in a DMX line, at the beginning, at the end, or anywhere in the middle. When a fixture is assigned a DMX address of 1, the DMX controller knows to send DATA assigned to address 1 to that unit, no matter where it is located in the DMX chain.

DATA cable (DMX cable) requirements (for DMX operation):

This fixture can be controlled via DMX-512 protocol. The DMX address is set on the back of the unit. Your unit requires either a standard 3-pin or 5-pin XLR connector for data input/output, see images below.



Further DMX cables can be purchased from all good sound and lighting suppliers or Prolight Concepts dealers.

Please quote:	3-Pin:	CABL10 - 2m	CABL11 - 5m	CABL12 - 10m
	5-Pin:	CABL185 - 2m	CABL187 - 5m	CABL188 - 10m

Also remember that DMX cable must be daisy chained and cannot be split.

Notice:

Be sure to follow the diagrams below when making your own cables. Do not connect the cables shield conductor to the ground lug or allow the shield conductor to come in contact with the XLRs outer casing. Grounding the shield could cause a short circuit and erratic behaviour.

Pin Configuration	
3-Pin	5-Pin
	Pin 1 - Ground
	Pin 2 - Negative
	Pin 3 - Positive
-	Pin 4 - N/C
-	Pin 5 - N/C

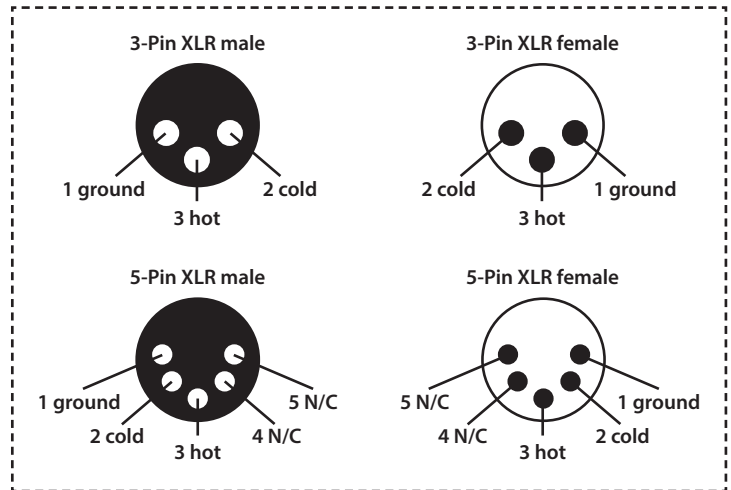
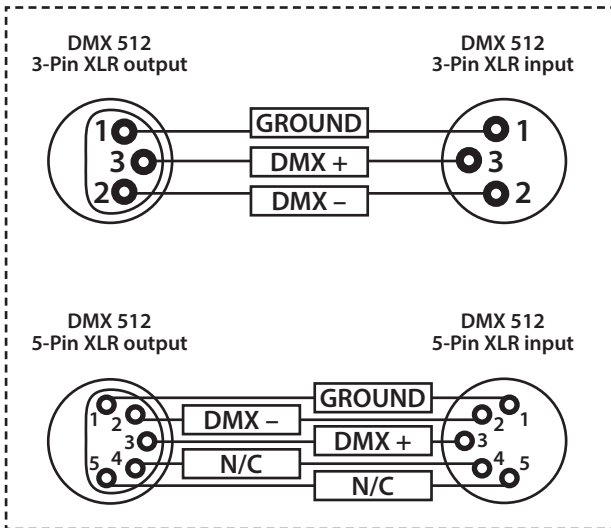

Line termination:

When longer runs of cable are used, you may need to use a terminator on the last unit to avoid erratic behaviour.

Using a cable terminator will decrease the possibilities of erratic behaviour.

(3-pin - Order ref: CABL90,
5-pin - Order ref: CABL89)

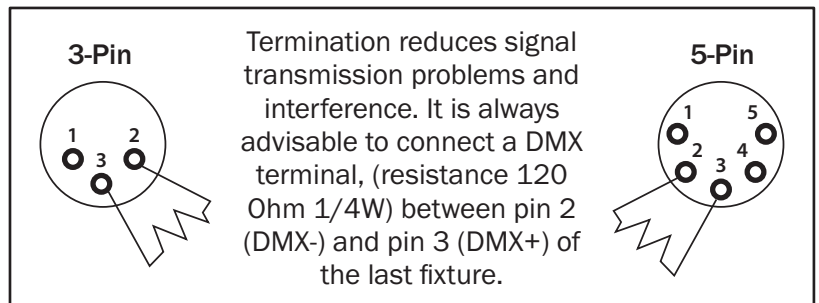

5-pin XLR DMX connectors:

Some manufactures use 5-pin XLR connectors for data transmission in place of 3-pin. 5-pin XLR fixtures may be implemented in a 3-pin XLR DMX line. When inserting standard 5-pin XLR connectors in to a 3-pin line a cable adaptor must be used. The diagram below details the correct cable conversion.

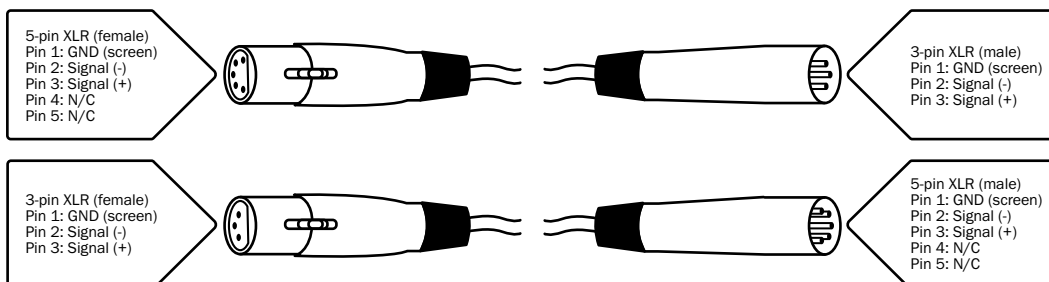



***Correct Disposal of this Product
(Waste Electrical & Electronic Equipment)***

**(Applicable in the European Union and other European countries
with separate collection systems)**

This marking shown on the product or its literature, indicates that it should not be disposed with other household wastes at the end of its working life. To prevent possible harm to the environment or human health from uncontrolled waste disposal, please separate this from other types of wastes and recycle it responsibly to promote the sustainable reuse of material resources.

Household users should contact either the retailer where they purchased this product, or their local government office, for details of where and how they can take this item for environmentally safe recycling.

Business users should contact their supplier and check the terms and conditions of the purchase contract. This product should not be mixed with other commercial wastes for disposal.

