

eNODE-4

DMX distribution over Ethernet



Overview

Designed to streamline your lighting control installations, this new eDMX node features 4 DMX outputs and PoE (Power over Ethernet) in a compact, DIN-rail form factor.

Once configured through the ESA Pro 2 software, eNODE-4 integrates with the DINA-DR1 and DINA-DR1 LITE, allowing you to extend the number of DMX outputs through sACN.

nicolaudie.com/enode-4

Key Features

- Converts eDMX to DMX
- Outputs up to 4 DMX universes
- Ethernet (PoE) connectivity
- DIN-rail form factor
- On-screen device status
- Configure with Hardware Manager and ESA Pro 2
- Compatible with DINA-DR1 and DINA-DR1 LITE
- Up to 50 eNODE-4 on the same network

Technical Data

Input Power	PoE / 8-15V DC / USB C
Output Protocol	DMX
Input Protocol	sACN
Programmability	PC, Mac
Connections	USB C / Ethernet / PoE IEEE 802.3 at / af 1 DC power input
Screen	
Environment	0C to 50C
Dim / Weight	120x80x70mm, 150g
Standards	CE, FCC, RoHS

Connections

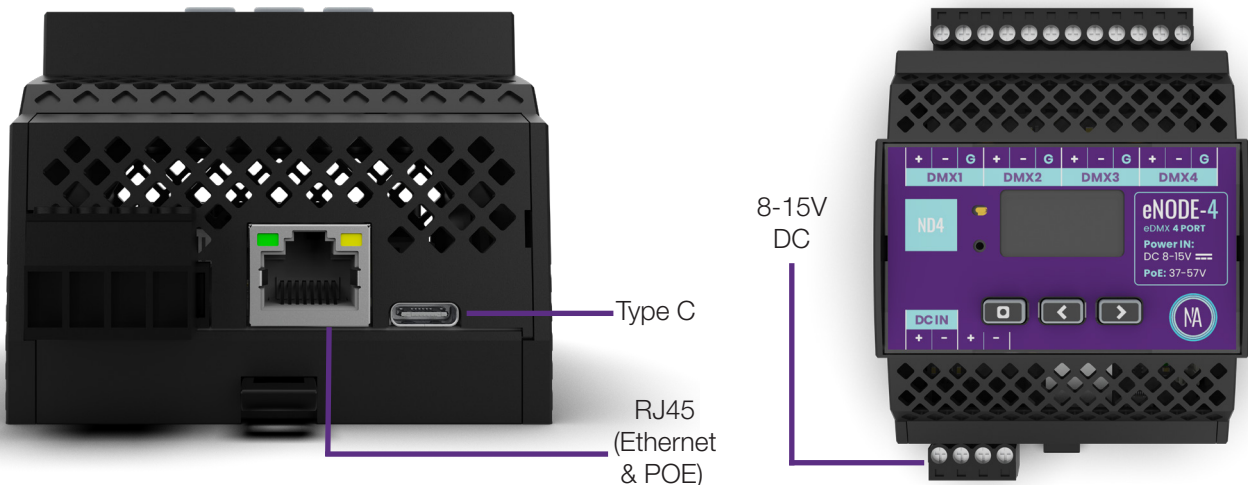

DMX distribution over Ethernet		eNODE-4	
Technical datasheet	Revision date 19 June 2026	www.nicolaudie.com	V 0.1

Installation

1. Mount a DIN Rail or DIN Rail Enclosure to a wall.

2. Connect the wires

Power: Connect 12V DC supply. The eNODE-4's voltage range is between 8V and 15V. Be sure not to invert the + and the ground. Optionally, you can connect the power supply using the DINA's power through connection.

Connection to controller: You can connect the eNODE-4 to the DINA using an Ethernet cable.

3. Clip the eNODE-4 onto the DIN Rail

On the back of the interface housing is a channel designed to accept a DIN Rail with a black plastic clip which secures the interface.

To mount: Slide the mounting teeth behind the top of the rail and then rotate downwards to engage the clip.

To dismount: At the lower edge of the interface you will see a plastic clip. Pull this down to release interface from the rail.

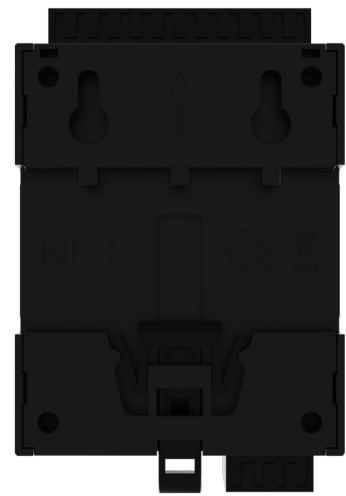

Setting up the eNODE-4

Network connection

1. In case you are using a router or a switch with DHCP you should make sure that the DHCP on both devices is enabled. This setting can be found in the Ethernet tab of the Hardware Manager app.
2. In case you are using a router or a switch without DHCP you should manually configure the network settings. This can be done in the Ethernet tab of the Hardware Manager app.
3. You can make a direct Ethernet connection between the eNODE-4 and your DMX controller. In this case you don't need a router or a switch. In the Ethernet tab of the Hardware Manager app you should disable the DHCP setting and enter valid network settings for both devices. On the next page we are giving example settings.

4. Configuration in ESA Pro 2

You can attach the eNODE-4 to the DINA-DR1 in the Nodes tab of the Device Import window in ESA Pro 2.

If the DHCP setting is disabled, you need to configure the eNODE-4 manually in ESA Pro 2. Go to Stand Alone -> Look at the Devices tab -> Unfold the DINA-DR1 with the arrow on the left side and select the eNODE-4 that you want to configure. In the Connection setting choose 'IP Address' and put in the IP Address from Hardware Manager.

If the DHCP setting is enabled, you don't need to configure anything in ESA Pro 2.

DMX distribution over Ethernet		eNODE-4	
Technical datasheet	Revision date 19 June 2026	www.nicolaudie.com	V 0.1

Example settings for making a direct connection between the eNODE-4 and DINA-DR1.

HardwareManager

Connection Firmware Diagnostic ?

ENODE1A DEFAULT 3801059

SIUDI11A SLESA-U11 1007546

DINA1 DINA-DR1 470978

I/O - Ports

Clock

Settings

Ethernet

StandAlone

Default adapter

Informations:

Current IP Address 169.254.126.237

Current Network Mask 255.255.0.0

Current Gateway 0.0.0.0

Current DNS server 8.8.8.8, 8.8.8.8, 8.8.8.8, 8.8.8.8

MAC 18:86:3A:01:8A:70

Configuration:

Enable

DHCP

Ip 169.254.126.237

Network Mask 255.255.0.0

DNS server 1 8.8.8.8

Gateway 0.0.0.0

Send Configuration

Connectivity:

Test Test not yet performed

Not connected

Login

Open advanced settings

HardwareManager

Connection Firmware Diagnostic ?

ENODE1A DEFAULT 3801059

SIUDI11A SLESA-U11 1007546

DINA1 DINA-DR1 470978

Security

DMX In/Out

I/O - Ports

Settings

Ethernet

Default adapter

Informations:

Current IP Address 169.254.126.238

Current Network Mask 255.255.0.0

Current Gateway 0.0.0.0

Current DNS server 8.8.8.8, 8.8.8.8, 8.8.8.8, 8.8.8.8

MAC 18:86:3A:05:D0:7D

Configuration:

Enable

DHCP

Ip 169.254.126.238

Network Mask 255.255.0.0

DNS server 1 8.8.8.8

Gateway 0.0.0.0

Send Configuration

Connectivity:

Test Test not yet performed

Not connected

Login

Open advanced settings

DMX distribution over Ethernet		eNODE-4	
Technical datasheet	Revision date 19 June 2026	www.nicolaudie.com	V 0.1

Screen

This section is dedicated to the eNODE-4's screen. You can switch between the different tabs by using the three navigation buttons.

The INFOS tab displays the device's serial number and its firmware version.

INFOS

```
ENODE 1A 3800007
ND4-MTP-1
FIRMWARE :
1.01-336ff03
2026-03-02 13:38:16
```

The ETHERNET tab contains the following information: DHCP, IP address, Mask, Link and MAC address.

ETHERNET

```
DHCP ON
IP 192.168.1.170
MASK 255.255.255.0
LINK 100 Mb/s
MAC 18:86:3A:05:CC:61
```

The OUTPUTS tab shows which of the eNODE-4's outputs are working.

OUTPUTS

```
1 | DINA 1B | sACN | 
2 | DINA 1B | sACN | 
3 | DINA 1B | sACN | 
4 | DINA 1B | sACN | 
```

Each output has its own tab. There you can see the IP address of the DMX controller that is using this output.

OUTPUT 1 sACN

```
DMX 1 
SOURCE DINA 1B
169.254.188.106
PRIORITY 100
UNIVERSE 00001
```

If the eNODE-4 is open in one of our softwares, the display is locked onto the LIVE tab.

LIVE

```
ENODE 1A 3800007
MODE ETH
IP 192.168.1.170
```

