

LEDj

PRO DMX Tri LED Starcloth Systems User Manual



Order codes:

6 x 3m Black Starcloth - STAR11

6 x 3m Black Starcloth System - STAR12

8 x 4m Black Starcloth System - STAR13

Starcloth Controller - STAR20

WARNING

FOR YOUR OWN SAFETY, PLEASE READ THIS USER MANUAL CAREFULLY BEFORE YOUR INITIAL START-UP!

- Before your initial start-up, please make sure that there is no damage caused during transportation.
- Should there be any damage, consult your dealer and do not use the equipment.
- To maintain the equipment in good working condition and to ensure safe operation, it is necessary for the user to follow the safety instructions and warning notes written in this manual.
- Please note that damages caused by user modifications to this equipment are not subject to warranty.



IMPORTANT:

The manufacturer will not accept liability for any resulting damages caused by the non-observance of this manual or any unauthorised modification to the equipment.

- Never let the power cable come into contact with other cables. Handle the power cable and all mains voltage connections with particular caution!
- Never remove warning or informative labels from the unit.
- Do not open the equipment and do not modify the unit.
- Do not connect this equipment to a dimmer pack.
- Do not switch the equipment on and off in short intervals, as this will reduce the system's life.
- Only use the equipment indoors.
- Do not expose to flammable sources, liquids or gases.
- Always disconnect the power from the mains when equipment is not in use or before cleaning! Only handle the power-cable by the plug. Never pull out the plug by pulling the power-cable.
- Make sure that the available mains supply voltage is between 100~250V AC, 50/60Hz.
- Make sure that the power cable is never crimped or damaged. Check the equipment and the power cable periodically.
- If the equipment is dropped or damaged, disconnect the mains power supply immediately and have a qualified engineer inspect the equipment before operating again.
- If the equipment has been exposed to drastic temperature fluctuation (e.g. after transportation), do not connect power or switch it on immediately. The arising condensation might damage the equipment. Leave the equipment switched off until it has reached room temperature.
- If your product fails to function correctly, stop use immediately. Pack the unit securely (preferably in the original packing material), and return it to your Prolight dealer for service.
- Only use fuses of same type and rating.
- To clean the cloth, disconnect the mains power supply and then wipe with a damp cloth. Do not immerse in liquid. The cloth will require monthly cleaning. Do not use alcohol or solvents. Connections and LEDs must be kept clean and dry at all times.
- Repairs, servicing and power connection must only be carried out by a qualified technician. THIS UNIT CONTAINS NO USER SERVICEABLE PARTS.
- This starcloth and/or controller is for professional use only - it is not designed for or suitable for household use. The product must be installed by a qualified technician in accordance with local territory regulations. The safety of the installation is the responsibility of the installer. The fixture presents risks of severe injury or death due to fire hazards, electric shock and falls.
- Please take care when unfolding the cloth for the first time along with handling and transporting as snagging the cloth could cause connections inside to come loose.
- Warning! Risk Group 2 LED product according to EN 62471. Do not view the light output with optical instruments or any device that may concentrate the beam.
- WARRANTY: Two years from date of purchase.

OPERATING DETERMINATIONS

If this equipment is operated in any other way, than those described in this manual, the product may suffer damage and the warranty becomes void. Incorrect operation may lead to danger e.g: short-circuit, burns and electric shocks etc. Do not endanger your own safety and the safety of others! Incorrect installation or use can cause serious damage to people and/or property.

Starcloth Systems

LEDJ LED Starcloths can be used for stage backdrops in theatres, concerts, and special events. Tri-colour LEDs are distributed across the surface of the black cloth and chase or twinkle according to the controller mode selection. Brighter, more durable and reliable than any other starcloths on the market, LEDJ remains the market leader in LED starcloths. Our starcloths are made with a random spacing arrangement which gives a more naturalistic pattern, to actually look more like the night sky.

Model	LEDs	Cloth colour	Order code
6 x 3m Tri LED Black Starcloth	128 x 5mm tri-colour LEDs	Black cloth	STAR11
6 x 3m Tri LED Black Starcloth System	128 x 5mm tri-colour LEDs	Black cloth	STAR12
8 x 4m Tri LED Black Starcloth System	192 x 5mm tri-colour LEDs	Black cloth	STAR13
Starcloth Controller	-	-	STAR20

- Hanging tabs on 3 sides
- Fire retardent material
- DMX channels: 7 or 28 selectable
- Sound active, auto and master/slave modes
- 4 push button menu with LCD display
- PowerCON input
- 3-Pin XLR DMX input/output
- 5-Pin XLR DMX input/output

Specifications	
Power supply	100~250V, 50/60Hz
Fuse	F2A 250V
Dimensions	6 x 3m - STAR11 & STAR12
	8 x 4m - STAR13
	61 x 271 x 178mm - STAR20
Weight	13.5kg - STAR11
	14.7kg - STAR12
	24.2kg - STAR13
	1.2kg - STAR20

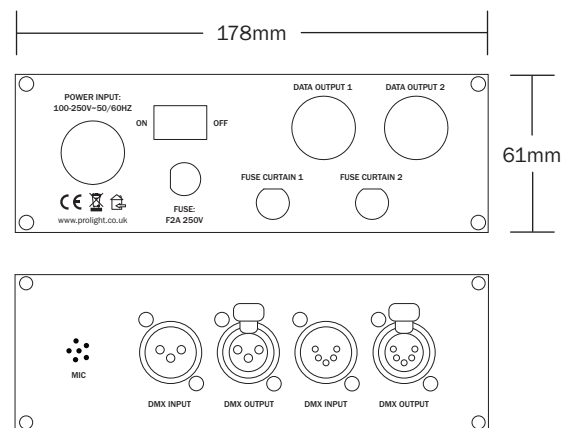
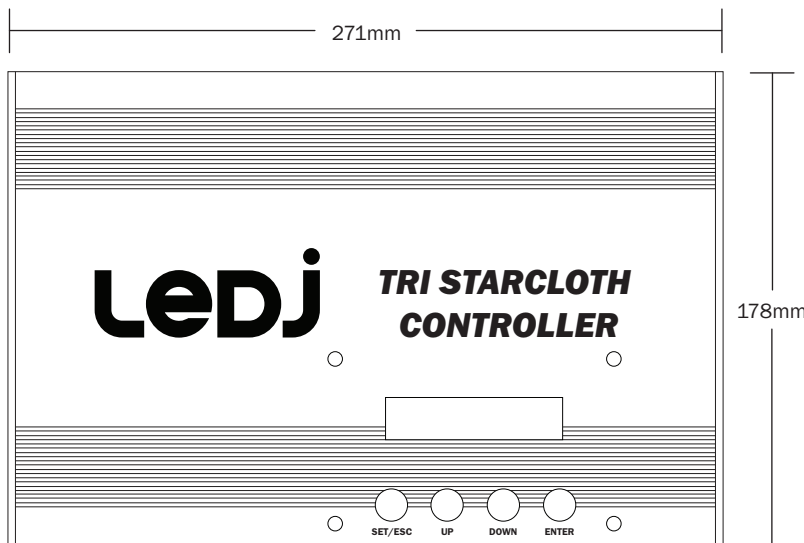

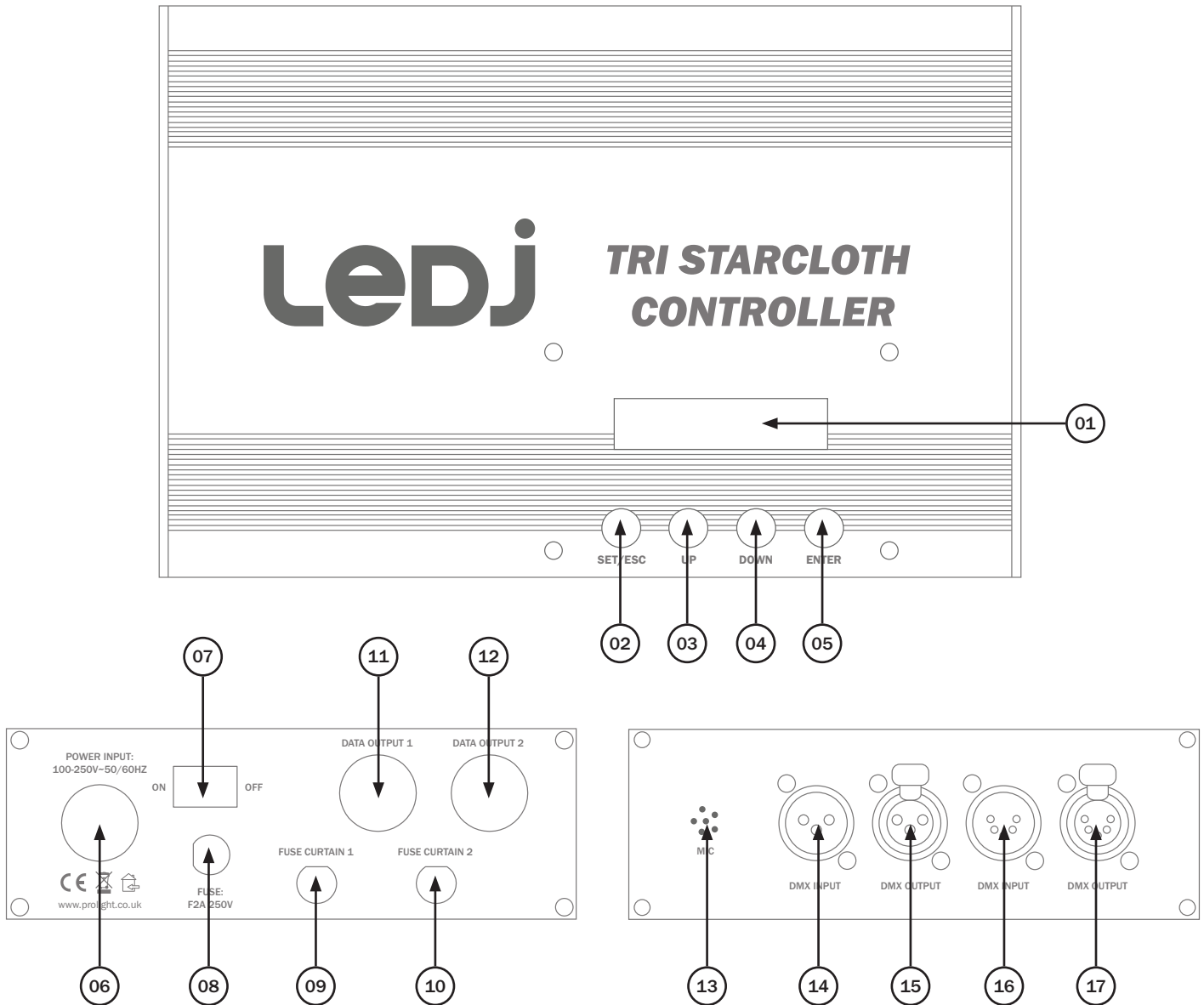

- 01 - LCD display
- 02 - SET/ESC button
- 03 - ENTER button
- 04 - UP button
- 05 - DOWN button
- 06 - PowerCON input

- 07 - On/off switch
- 08 - Fuse F2A 250V
- 09 - Fuse curtain 1
- 10 - Fuse curtain 2
- 11 - Data output 1
- 12 - Data output 2

- 13 - Mic
- 14 - 3-Pin DMX input
- 15 - 3-Pin DMX output
- 16 - 5-Pin DMX input
- 17 - 5-Pin DMX output

In the box (STAR11):
1 x starcloth
1 x user manual &
1 x 4-Pin XLR cable for
connection to the controller

In the box (STAR12/13):
1 x starcloth,
1 x power cable,
1 x controller &
1 x user manual

In the box (STAR20):
1 x controller &
1 x user manual

Colour macro mode

To access colour macro mode press the “UP/DOWN” buttons to show “MACRO” on the LCD display. It will now run through its built-in programmes in either of the selected sound or auto modes. Press the “ENTER” button to adjust the colour macro steps from 1-62 using the “UP/DOWN” buttons. Press the “ENTER” button to save your setting.

Static colour mode

To choose from any of the 7 static colours press the “UP/DOWN” buttons to scroll through from “BLACK MASTER” to “WHITE MASTER” on the LCD display. To change the settings on any of the chosen colour press the “ENTER” button twice and use the “UP/DOWN” buttons to adjust any of the “brightness”, “dimming mode”, “colour adjust” and “strobe”.

Please note that all settings are from 000-255 (000 = off, 255 = full on).

Press the “ENTER” button to save your setting.

Built in programmes

To access any of the 10 built-in programmes press the “UP/DOWN” buttons to scroll through from “PROGRAMME 1” to “PROGRAMME 10” on the LCD display. To adjust the dimming, speed or strobe of the chosen programme press the “ENTER” button twice and use the “UP/DOWN” buttons to scroll through the options and press the “ENTER” button to enter each option. Now use the “UP/DOWN” buttons to adjust the values from 000 - 255.

Press the “ENTER” button to save your setting.

DMX mode:

To access the DMX mode press the “UP/DOWN” buttons to show “ADDR:001” on the LCD display. To set the DMX address press the “ENTER” button twice to show “DMX ADDRESS” on the LCD display and press the “ENTER” button and use the “UP/DOWN” buttons to set the address from 001 - 512. Now press the “ENTER” button to save your setting.

In DMX mode there are break options so you can set up how the fixture will operate if the DMX signal breaks. To set this up while you are in the DMX mode press the “ENTER” button twice to access the DMX menu and use the “UP/DOWN” buttons to show “DMX BREAK” on the LCD display. Press the “ENTER” button and use the “UP/DOWN” buttons scroll through the options and press “ENTER” to save your setting.

Stop Run - Will stop the cloth running the current program and stay static when the DMX signal breaks.

Hold Run - Will continue to run the current program when the DMX signal breaks.

Auto Run - Will switch to auto run automatically and run the built-in programmes randomly.

Sound Run - Will switch to sound activation automatically and run the built-in programmes randomly.

To select one of the 7 or 28 DMX channel modes use the “UP/DOWN” buttons to show “CHANNEL SELECT” on the LCD display and use the “UP/DOWN” buttons to scroll through the two DMX channel options. Press the “ENTER” button to save your setting.

Master/slave mode:

To set the unit as the master or slave press the “**SET/ESC**” button to show “**SET MENU**” on the LCD display. Now press the “**ENTER**” button and use the “**UP/DOWN**” buttons to scroll to “**MASTER & ALONE**”. Press the “**ENTER**” button and use the “**UP/DOWN**” buttons to switch from “**MASTER**” or “**ALONE**” (SLAVE). Press the “**ENTER**” button to save your setting.

Restore default mode:

In this mode you can restore your settings to its original default settings. To do this press the “**SET/ESC**” button to show “**SET MENU**” on the LCD display. Now press the “**ENTER**” button and use the “**UP/DOWN**” buttons to scroll to “**RELOAD DEFAULT**”. Now press the “**ENTER**” button and use the “**UP/DOWN**” buttons to select either “**ON**” or “**OFF**”.

Press the “**ENTER**” button to save your setting.

Auto & sound mode:

In this mode you can have the built-in programmes running with either auto run or sound active.

To enter this mode press the “**SET/ESC**” button to show “**SET MENU**” on the LCD display.

Now press the “**ENTER**” button and use the “**UP/DOWN**” buttons to scroll to “**AUTO & SOUND**”.

Now press the “**ENTER**” button and use the “**UP/DOWN**” buttons to select either “**AUTO**” or “**SOUND**”.

Press the “**ENTER**” button to save your setting.

Clear display mode:

In this mode you can have the LCD display to slowly fade out slowly or to stay on constantly. To enter this mode press the “**SET/ESC**” button to show “**SET MENU**” on the LCD display. Now press the “**ENTER**” button and use the “**UP/DOWN**” buttons to scroll to “**CLEAR DISPLAY**” Now press the “**ENTER**” button and use the “**UP/DOWN**” buttons to select either “**DELAY OFF**” or “**ALWAYS ON**”.

Press the “**ENTER**” button to save your setting.

Key lock mode:

In this mode you can lock the LCD display so no unwanted users can change the settings. To enter this mode press the “**SET/ESC**” button to show “**SET MENU**” on the LCD display. Now press the “**ENTER**” button and use the “**UP/DOWN**” buttons to scroll to “**KEY LOCK**”. Now press the “**ENTER**” button and use the “**UP/DOWN**” buttons to select either “**ON**” or “**OFF**”.

Press the “**ENTER**” button to save your setting.

Please note: To unlock the display you must press the following sequence:

1: SET/ESC, 2: DOWN, 3: UP, 4: ENTER

Information mode:

In this mode you see the information for web address, name of the product, telephone number, date and time and the serial number. To enter this mode press the “**SET/ESC**” button to show “**INFORMATION**” on the LCD display. Now press the “**ENTER**” button and use the “**UP/DOWN**” buttons to scroll through each bit of information.

Fixture usage:

In this mode you see how long the unit has been in use for per session and total time. To enter this mode press the “**SET/ESC**” button to show “**MACHINE TIMER**” on the LCD display. Now press the “**ENTER**” button and use the “**UP/DOWN**” buttons to scroll through the time options either “**TOTAL TIME**” or “**CLEAR TIME**”. To display the time usage press the “**ENTER**” button.

7 channel mode:

Channel	Value	Function
1	000-255	Master dimmer 0-100%
2	000-009	No function
	010-255	Strobe (slow-fast)
3	000-049	RGB mode
	050-059	Blackout
	060-069	Red
	070-079	Green
	080-089	Blue
	090-099	Yellow
	100-109	Cyan
	110-119	Purple
	120-129	White
	130-139	Programme 1
	140-149	Programme 2
	150-159	Programme 3
	160-169	Programme 4
	170-179	Programme 5
	180-189	Programme 6
	190-199	Programme 7
	200-209	Programme 8
	210-219	Programme 9
220-229	Programme 10	
230-239	Colour macros	
240-249	Sound active	
250-255	No function	
4	000-004	Normal Speed
	005-255	Speed (slow-fast)
5	000-255	Red 0-100%
6	000-255	Green 0-100%
7	000-255	Blue 0-100%

28 channel mode:

Channel	Value	Function
1	000-255	Master dimmer 0-100%
2	000-009	No function
	010-255	Strobe (slow-fast)
3	000-049	RGB mode
	050-059	Blackout
	060-069	Red
	070-079	Green
	080-089	Blue
	090-099	Yellow
	100-109	Cyan
	110-119	Purple
	120-129	White
	130-139	Programme 1
	140-149	Programme 2
	150-159	Programme 3
	160-169	Programme 4
	170-179	Programme 5
	180-189	Programme 6
	190-199	Programme 7
	200-209	Programme 8
	210-219	Programme 9
	220-229	Programme 10
	230-239	Colour macros
	240-249	Sound active
	250-255	No function

4	000-004	Normal Speed
	005-255	Speed (slow-fast)
5	000-255	Red 1
6	000-255	Green 1
7	000-255	Blue 1
8	000-255	Red 2
9	000-255	Green 2
10	000-255	Blue 2
11	000-255	Red 3
12	000-255	Green 3
13	000-255	Blue 3
14	000-255	Red 4
15	000-255	Green 4
16	000-255	Blue 4
17	000-255	Red 5
18	000-255	Green 5
19	000-255	Blue 5
20	000-255	Red 6
21	000-255	Green 6
22	000-255	Blue 6
23	000-255	Red 7
24	000-255	Green 7
25	000-255	Blue 7
26	000-255	Red 8
27	000-255	Green 8
28	000-255	Blue 8

Setting the DMX address:

The DMX mode enables the use of a universal DMX controller. Each fixture requires a “start address” from 1- 511. A fixture requiring one or more channels for control begins to read the data on the channel indicated by the start address. For example, a fixture that occupies or uses 7 channels of DMX and was addressed to start on DMX channel 100, would read data from channels: 100,101,102,103,104,105 and 106. Choose a start address so that the channels used do not overlap. E.g. the next unit in the chain starts at 107.

DMX 512:

DMX (Digital Multiplex) is a universal protocol used as a form of communication between intelligent fixtures and controllers. A DMX controller sends DMX data instructions from the controller to the fixture. DMX data is sent as serial data that travels from fixture to fixture via the DATA “IN” and DATA “OUT” XLR terminals located on all DMX fixtures (most controllers only have a data “out” terminal).

DMX linking:

DMX is a language allowing all makes and models of different manufactures to be linked together and operate from a single controller, as long as all fixtures and the controller are DMX compliant. To ensure proper DMX data transmission, when using several DMX fixtures try to use the shortest cable path possible. The order in which fixtures are connected in a DMX line does not influence the DMX addressing. For example; a fixture assigned to a DMX address of 1 may be placed anywhere in a DMX line, at the beginning, at the end, or anywhere in the middle. When a fixture is assigned a DMX address of 1, the DMX controller knows to send DATA assigned to address 1 to that unit, no matter where it is located in the DMX chain.

DATA cable (DMX cable) requirements (for DMX operation):

This fixture can be controlled via DMX-512 protocol. The DMX address is set on the back of the unit. Your unit and your DMX controller require a standard 3-pin XLR connector for data input/output, see image below.



Further DMX cables can be purchased from all good sound and lighting suppliers or Pro Light Concepts dealers.

Please quote:

CABL10 – 2m

CABL11 – 5m

CABL12 – 10m

Note: DMX cable must be daisy chained and cannot be split.

Notice:

Be sure to follow the diagrams below when making your own cables. Do not connect the cables shield conductor to the ground lug or allow the shield conductor to come in contact with the XLRs outer casing. Grounding the shield could cause a short circuit and erratic behaviour.

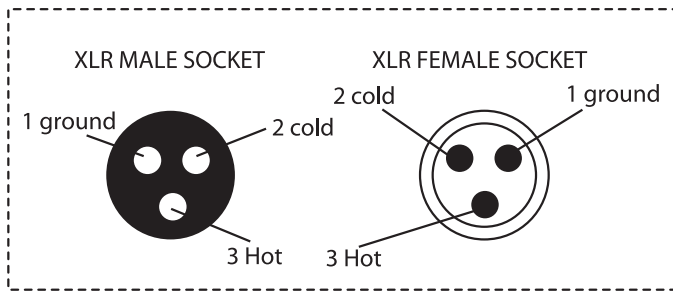
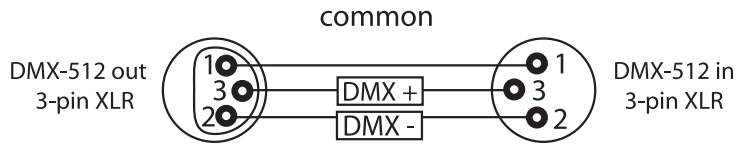

XLR Pin Configuration
Pin 1 = Ground
Pin 2 = Negative
Pin 3 = Positive

Special note:

Line termination:

When longer runs of cable are used, you may need to use a terminator on the last unit to avoid erratic behaviour.

Using a cable terminator will decrease the possibilities of erratic behaviour.

(3-pin - Order code: CABL90, 5-pin - Order code: CABL89)

Termination reduces signal transmission problems and interference. It is always advisable to connect a DMX terminal, (resistance 120 Ohm 1/4 W) between pin 2 (DMX-) and pin 3 (DMX+) of the last fixture.

5-pin XLR DMX connectors:

Some manufactures use 5-pin XLR connectors for data transmission in place of 3-pin. 5-pin XLR fixtures may be implemented in a 3-pin XLR DMX line. When inserting standard 5-pin XLR connectors in to a 3-pin line a cable adaptor must be used. The diagram below details the correct cable conversion.

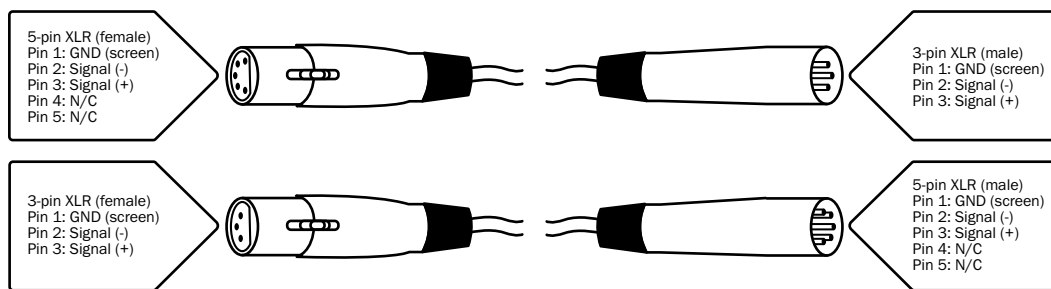



***Correct Disposal of this Product
(Waste Electrical & Electronic Equipment)***

**(Applicable in the European Union and other European countries
with separate collection systems)**

This marking shown on the product or its literature, indicates that it should not be disposed of with other household wastes at the end of its working life. To prevent possible harm to the environment or human health from uncontrolled waste disposal, please separate this from other types of wastes and recycle it responsibly to promote the sustainable reuse of material resources.

Household users should contact either the retailer where they purchased this product, or their local government office, for details of where and how they can take this item for environmentally safe recycling.

Business users should contact their supplier and check the terms and conditions of the purchase contract. This product should not be mixed with other commercial wastes for disposal.



LEDj